

DMX-LED-DIMMER X9HRX+

User Manual



Content

Important Notes	4
Description.....	5
Data sheet	7
Content	7
Connection with one power supply	8
Connection with several power supplies.....	9
Connection with single color and multi-color stripes	10
CTRL-Output (Energy-Save)	11
Cable Lengths	12
Status Display	13
Settings.....	14
Key Lock.....	14
Menu Guide	15
DMX-Address	16
Display Switch Off	16
DMX FAIL Action	17
Operation Modes	18
Personality 1: 9Ch. Dimmer	19
Personality 2: 9Ch. Dimmer + Master	19
Personality 3: 9Ch. Dimmer + RGB-Master	19
Personality 4: 9Ch. Dimmer + RGBW-Master	19
Personality 5: 9Ch. Dimmer 16Bit	20
Personality 6: 9Ch. Dimmer 16Bit + Master	20
Personality 7: 9Ch. Dimmer 16Bit + RGB-Master	20
Personality 8: 9Ch. Dimmer 16Bit + System-Master	20
Personality 9: 4x CCT-Control	21
RDM	22
Configure the Dimming-Curve (Curve Definition).....	26
Setting the output frequency	27
Lock device settings.....	28
SubDevice-Mode	29
Firmware-Update	31
Factory Reset	32
Dimensions.....	33
Equipment	34
Revision History.....	35

	3
CE-Conformity	36
Disposal.....	36
Risk-Notes	37

Important Notes



For your own safety, please read this user manual and warnings carefully before installation.



A firmware update is recommended after receipt the product. This is the only way to ensure that the device has the latest version. You can find the latest firmware on the homepage.

Description

The **DMX LED Dimmer X9HRX+** is a 9-channel LED driver with 16-bit grayscale adaptive pulse density modulation (APDM) and a high output frequency of up to 8kHz at the same time.

Thanks to the special APDM technology in combination with the optimized 48V LED drivers, the DMX LED dimmer X9HRX+ is perfectly suited for controlling RGB, RGBW or even single-color W stripes.

9 Outputs

The DMX-LED-Dimmer X9HRX+ has 9 outputs to which LEDs can be connected. All outputs are designed in the same way so single color, RGB or RGBW LEDs can be connected.

High Power Outputs

The outputs can drive a current up to 10A. So it is possible to connect a maximum load of 120W (12V) / 240W (24V) / 240W (48V).

High efficiency

The 48V LED drivers are designed to allow the DMX LED Dimmer X9HRX to operate without active cooling (no fan).

0% up to 100% dimmable

The connected LEDs are dimmed by APDM from 0% to 100%.

For voltages from 12V up to 48V

The DMX-LED-Dimmer X9HRX+ operates with supply voltages from 12V up to 48V. The LED voltage can be different per output so that one DMX-LED-Dimmer X9HRX+ can control different LED systems.

DMX-FAIL Function

An adjustable DMX FAIL function offers the option to get in case of loss DMX signal the current state (HOLD) or predefined a preset value.

DMX-Master Dimmer

Optionally, another DMX channel can be activated as Master Dimmer (all outputs) or one master dimmer per RGB/RGBW group.

Adjustable Output Frequency

The output frequency at the LED outputs can be adjusted between 500Hz and 8000Hz via RDM.

Adjustable Dimming Curve

The dimming curves can be configured individually for each output.

RDM Support

The DMX-LED-Dimmer X9HRX+ allows configuration by RDM via DMX.

Free RDM-Software

To set the parameters via RDM, our free RDM Configurator software is available to download from our website www.dmx4all.de.

SubDevice-Mode

In SubDevice mode, each output is assigned its own DMX address and DMX FAIL behavior via RDM.

Touch-Control

The DMX-LED-Dimmer X9HRX+ is designed with 3 touch fields for operation and a 7-segment display.

RGB-Status-Display

The device status is shown via the RGB status display.

Firmware-Update-Function

In order to be able to use future functions, the DMX-LED-Dimmer X9HRX+ offers a firmware update function both via USB and RDM.

For DIN Rail Mounting

The design in a DIN rail housing with a width of 10.5cm / 6TE makes it easy to install in a control cabinet.

Data sheet

Power supply:	12-48V DC 80mA@12V / 100mA@24V (without connected LED load)
LED voltage:	12-48V DC (no AC voltage!)
Protocol:	DMX512 RDM
DMX Channels:	9 channels with 8Bit-controlling and Curve-Definition 18 channels with 16Bit-controlling + optional Master-Dimmer channels
DMX-FAIL:	Hold / 0%-100%
Output:	9 PWM-signal with 16Bit-resolution and APDM (Adaptive Pulse Density Modulation) common supply voltage
Output current:	max. 10A each output In sum 90A with all GND connections (direct from power supply)
Output power:	9x 120W (12V) / 9x 240W (24V) / 9x 240W (48V)
Masterdimmer:	No / Global / RGB / RGBW
PWM frequency:	500Hz / 1kHz / 2kHz / 4kHz / 8kHz
CTRL Output:	Control output for switching off the load power supply units (Energy-Save)
StandAlone Function:	9 internal Stand-Alone programs
Display:	7 segment display RGB LED
TOUCH-Control:	3 touch buttons
Connections:	Screw terminals
Dimension:	105mm x 90mm x 60mm

Content

- 1x DMX-LED-Dimmer X9HRX+
- 1x Quick manual german and english

Connection with one power supply

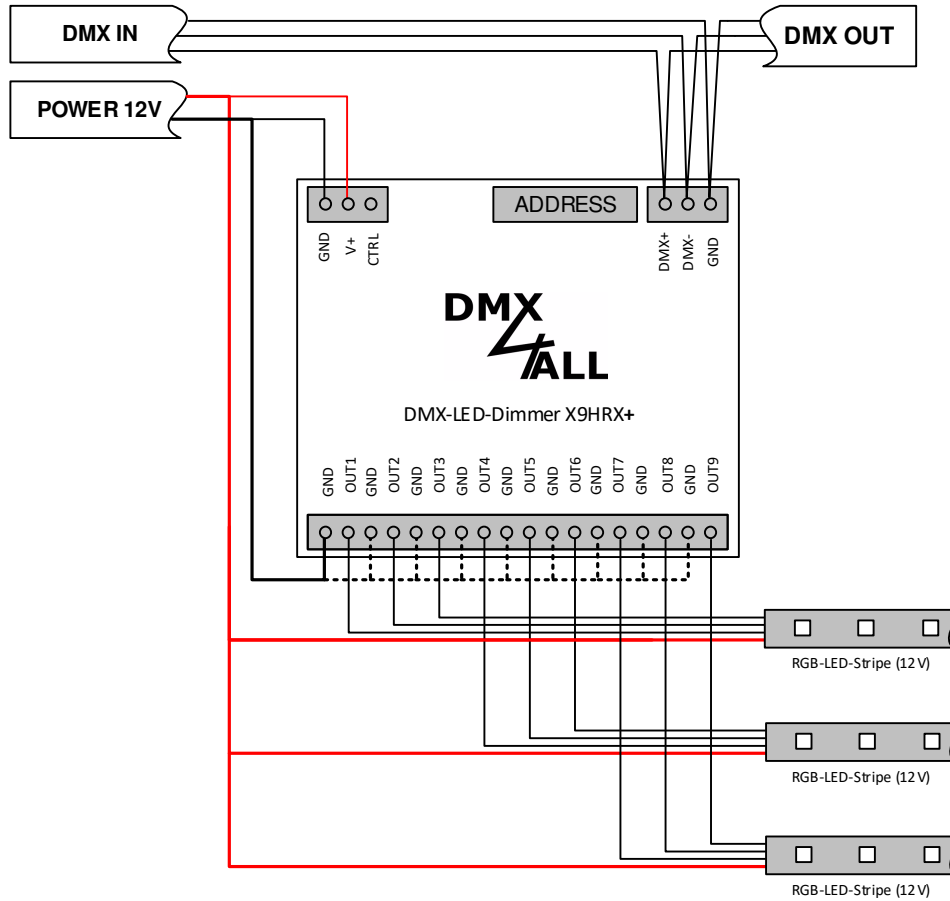

 Connections directly from the power supply unit depending on the required current of the LED strips!
 Use at least one GND connection for every 10A.

Connection with several power supplies

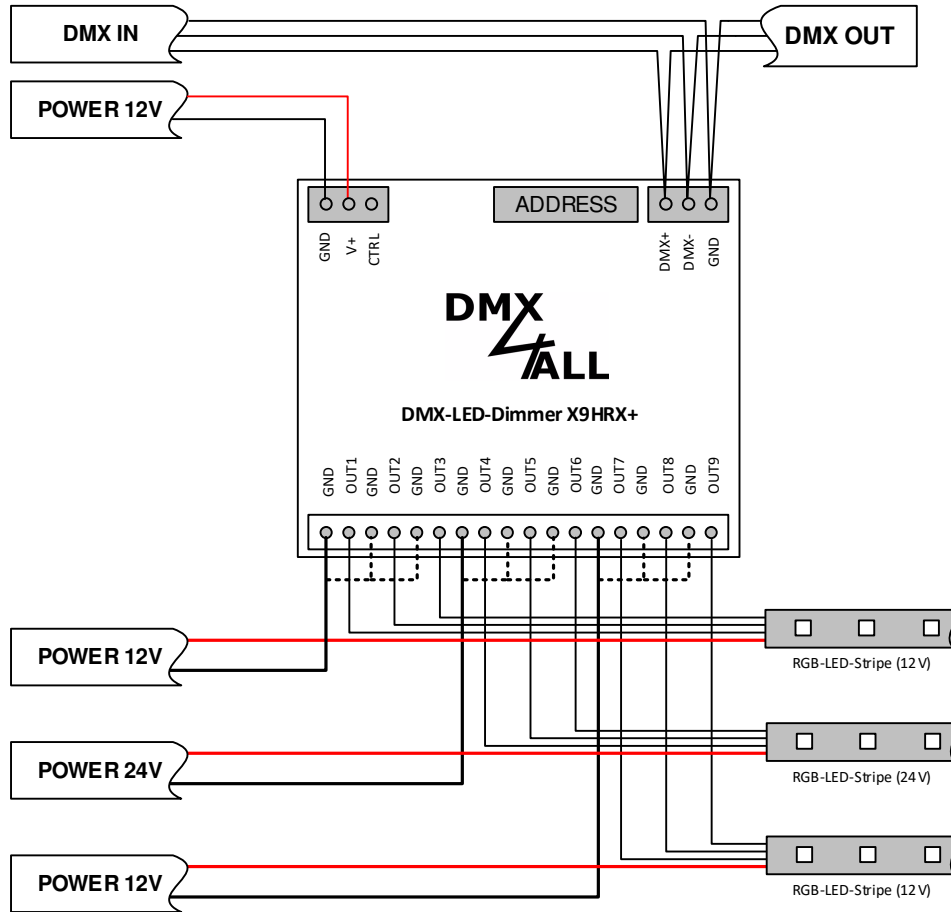

.....
 Connections directly from the power supply unit depending on the required current of the LED strips! Use at least one GND connection for every 10A.

Connection with single color and multi-color stripes

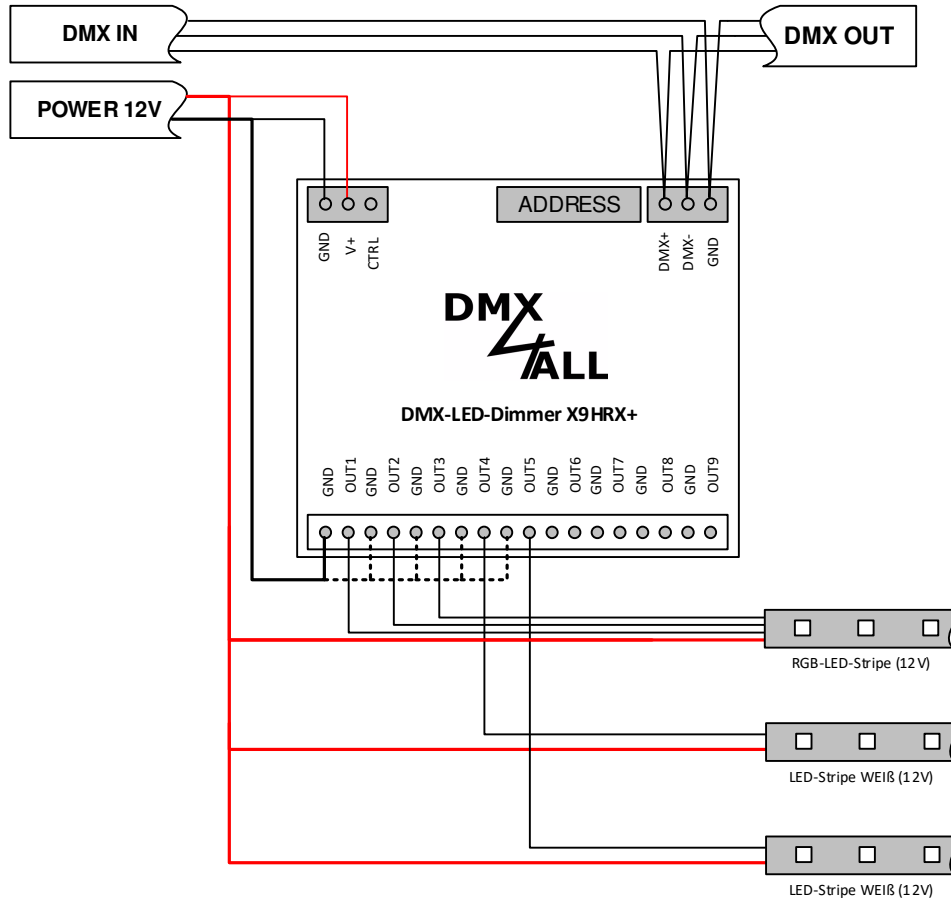

 Connections directly from the power supply unit depending on the required current of the LED strips!
 Use at least one GND connection for every 10A.

CTRL-Output (Energy-Save)

The **DMX-LED-Dimmer X9HRX+** has an Energy-Save control output (CTRL) which is able to run off the Load Power Supply of the LEDs.

If none of the outputs is activated for a period of 5 minutes or all DMX values are set to 0 for 5 minutes, the control output is switched off.

So, the power loss for power supply units that are not needed for a longer period of time can be avoided.

Example installation:

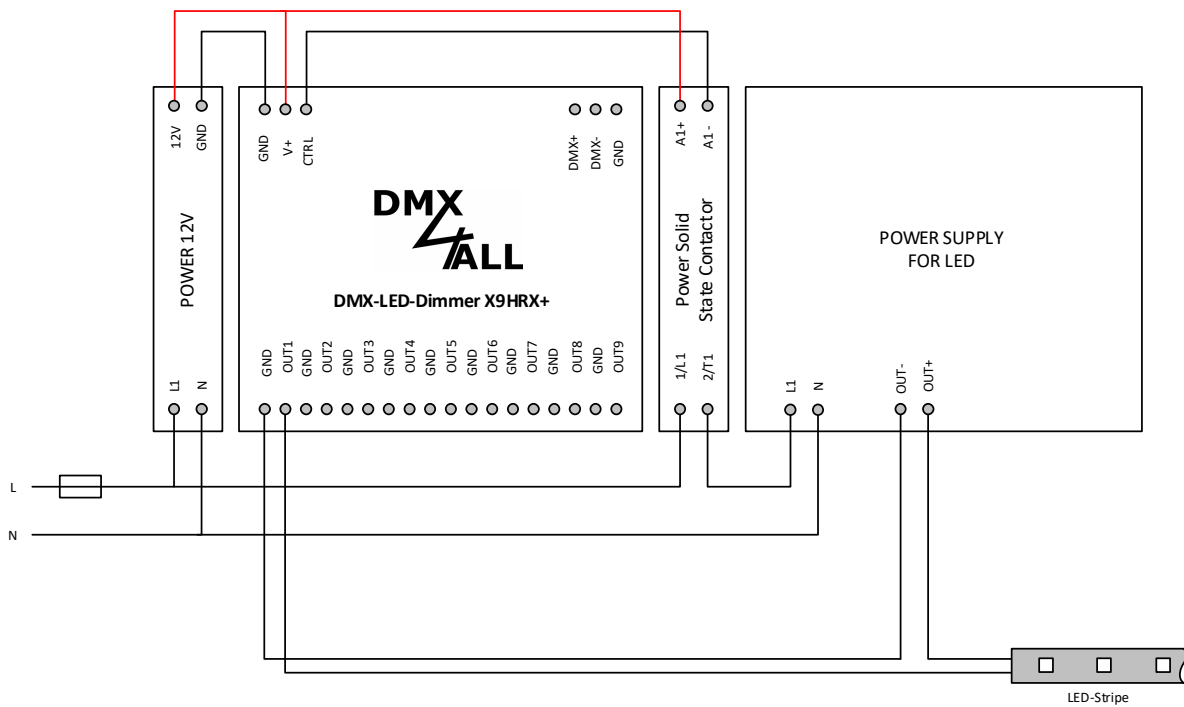

Cable Lengths

The DMX-LED-Dimmer X9HRX+ should be run with shortest possible cable lengths.

Because of the low operation voltage in LED installation the cable cross section is to choose as large as possible to keep the voltage drop as low as possible on the cable.

The cable cross section should be all the larger as the distance increases and the load increases.

The following cable lengths should not be exceeded:

From power supply to DMX-LED-Dimmer X9HRX+ → 1m

From DMX-LED-Dimmer X9HRX+ to LEDs → 10m

Status Display

The integrated RGB status display is a multifunction display showing the device status.

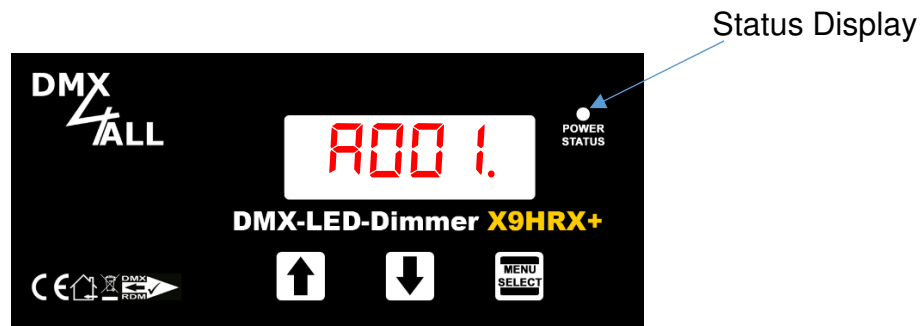

Off	Power supply not connected
RED lights	No DMX-Signal
GREEN lights	The device works normally A DMX-Signal is detected
BLUE flashes	The device works normally A RDM-Signal was processed
BLUE lights	The firmware update is carried out
PINK lights	The received firmware is checked

Settings

Either the settings can be made via RDM or directly at the DMX-LED-Dimmer X9HRX+ via the 3 buttons at the 7 segment display.

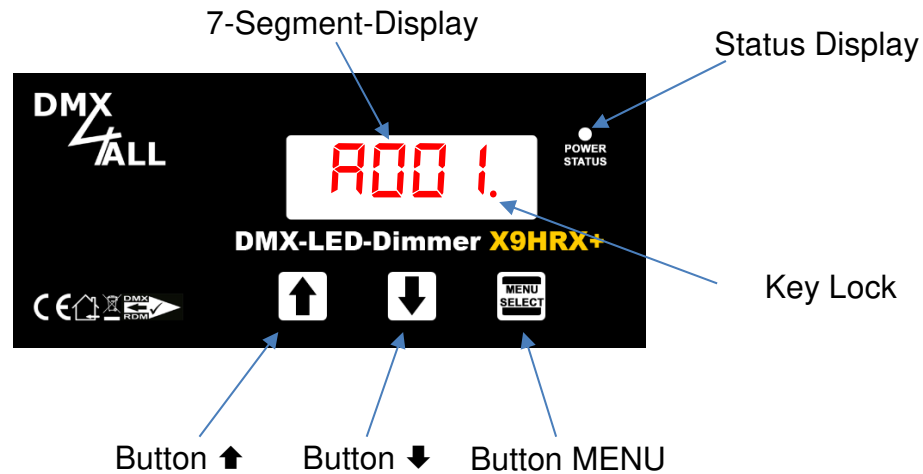

Key Lock

After turning on the DMX-LED-Dimmer X9HRX+ or if no button is pressed for ca. 15 seconds the key lock starts automatically and the set DMX start address is shown.

The activated key lock is displayed via a lighting dot right below in the display.

To release the key lock, any key must be pressed for ca. 3 seconds. During this time, the key lock indicator flashes until it finally goes out.

DMX-Address

Via the RDM parameter DMX_START_ADDRESS or directly at the device under menu \bar{R} the start address can be set.

By pressing the buttons \uparrow or \downarrow the start address can be set in a arrange of 1 and 512.

If \uparrow or \downarrow is pressed held, the start address increases or decreases until the button is pressed.



Display Switch Off

To avoid disturbing lighting points during the operation, the DMX-LED-Dimmer X9HRX+ display can be switched off.

The shutdown can occur manually or automatically.

Manually it takes place via the RDM parameter DISPLAY_LEVEL.

To activate the automatic shutdown the RDM parameter DISPLAY_AUTO_OFF is to select or the menu $\square FF$ directly at the device.

The time, after which the shutdown should take place is to select between 1 and 9 minutes or off (-) by pressing the buttons \uparrow or \downarrow .



The display shutdown is only in the normal operation (permanent applied DMX-Signal) possible after the set time runs out. If the DMX-Signal gets lost or a button is pressed at the device the display is switched on and the passed time is reset.

DMX FAIL Action

The **DMX-LED-Dimmer X9HRX+** has a DMX-FAIL function keeping the last switching state (HOLD) or set the predefined switching state to the set value.

In case of DMX fail the behavior can be set via the RDM parameter DMX_FAIL_MODE or directly at the device in the menu **F** .

Using the buttons **▲** or **▼** to set the value in range of 0 and 255. If **▲** or **▼** is pressed held, the value increases or decreases automatically until the button is pressed.

If the maximum value of 255 is reached, the hold function is activated by pressing **▲** again. Pressing **▼** again the hold function is deactivated again.

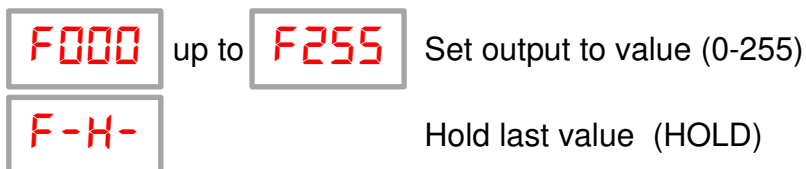
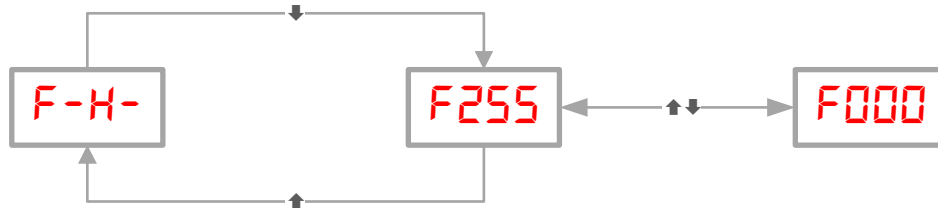

⚠ In case of a power fail the hold switching states are not restored with the hold function. In this case the values are set to 0 (OFF).

Operation Modes

The **DMX-LED-Dimmer X9HRX+** has several operation modes (Personality):

- Personality 1: 9Ch. Dimmer
- Personality 2: 9Ch. Dimmer + Master
- Personality 3: 9Ch. Dimmer + RGB-Master
- Personality 4: 9Ch. Dimmer + RGBW-Master
- Personality 5: 9Ch. Dimmer 16Bit
- Personality 6: 9Ch. Dimmer 16Bit + Master
- Personality 7: 9Ch. Dimmer 16Bit + RGB-Master
- Personality 8: 9Ch. Dimmer 16Bit + RGBW-Master
- Personality 9: 4x CCT-Control

The Personality is to set via the RDM-Parameter `DMX_PERSONALITY`.

Personality 1: 9Ch. Dimmer

In this operation mode each output is controlled with one DMX channel (8Bit). For each output there's a free programmable dim curve (LookUp table / Curve Definition) available, which displays the 8Bit-DMX value to the 16Bit solution of the output. The output characteristics are linear predefined and can be freely programmed.

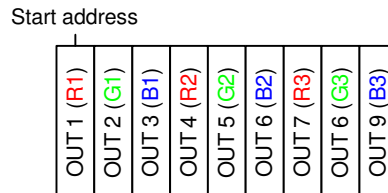

Personality 2: 9Ch. Dimmer + Master

Additionally, to Personality 1, the first DMX channel is used as master dimmer for all 9 outputs.

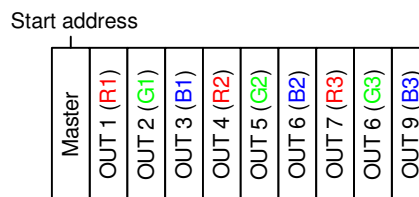

Personality 3: 9Ch. Dimmer + RGB-Master

In addition to Personality 1, one master dimmer is used for every 3 outputs (RGB group).

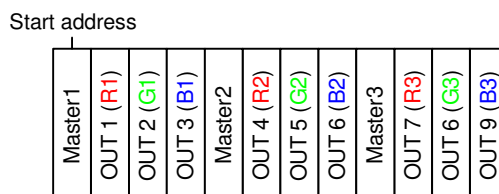

Personality 4: 9Ch. Dimmer + RGBW-Master

In addition to Personality 1, a master dimmer is added for every 4 outputs (RGBW group). Output 9 can be controlled via a single DMX channel.

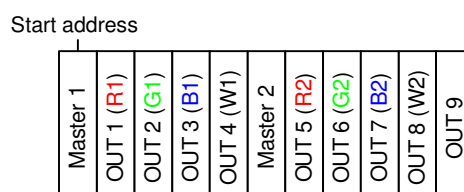

Personality 5: 9Ch. Dimmer 16Bit

In this operating mode, each output is controlled with two DMX channels (16Bit). Each output has a 16-bit resolution, which is shown directly via the DMX values. Two DMX channels are used for each output. The second DMX channel is fine adjustment.

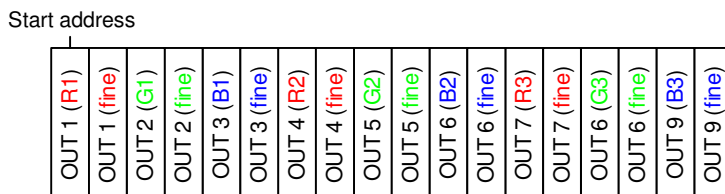

Personality 6: 9Ch. Dimmer 16Bit + Master

Additionally, to Personality 6 the first DMX channel is used as a master dimmer (8Bit) for all 9 outputs.

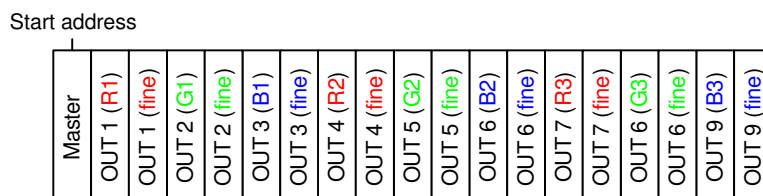

Personality 7: 9Ch. Dimmer 16Bit + RGB-Master

In addition to Personality 6, a master dimmer (8Bit) is added for every 3 outputs (RGB group).

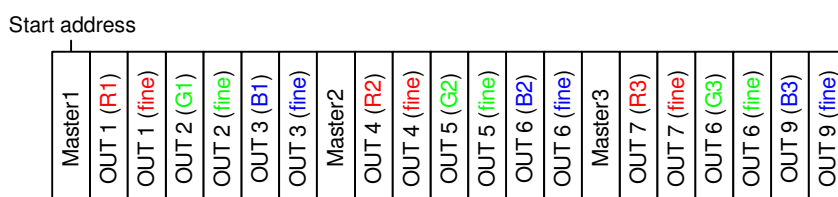

Personality 8: 9Ch. Dimmer 16Bit + System-Master

In addition to Personality 6, a master dimmer (8Bit) is added for every 4 outputs (RGBW group). Output 9 can be controlled via a single DMX channel.

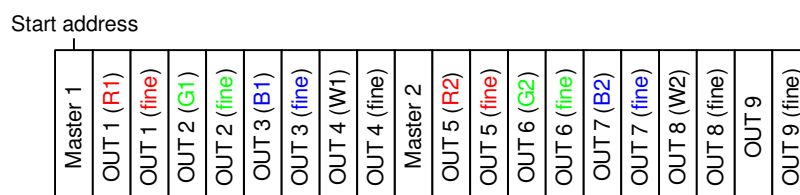

Personality 9: 4x CCT-Control

The CCT mode is especially created for cold-white and warm-white mixed light percentage.

Always, 2 outputs, one for cold-white and one for warm-white, are grouped. For these outputs the brightness is to set via the master channel and the mixing ratio via the CCT channel.

The outputs are grouped as follows:

	Cold white	Warm white
CCT group 1	OUT1	OUT2
CCT group 2	OUT3	OUT4
CCT group 3	OUT5	OUT6
CCT group 4	OUT7	OUT8

In sum, the DMX-LED-Dimmer X9HRX+ has 4 independent CCT groups taking the outputs 1 up to 8. Output 9 can be controlled via a single DMX channel.

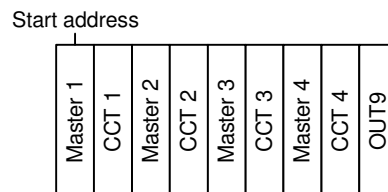

RDM

RDM is the short form for **R**emote **D**evice **M**anagement.

As soon as the device is within the system, device-dependent settings occur remotely via RDM command due to the uniquely assigned UID. A direct access to the device is not necessary.



If the DMX start address is set via RDM, all address switches at the DMX-LED-Dimmer X9HR must be set to OFF ! A DMX start address set by the address switches is always prior !

This device supports the following RDM commands:

Parameter ID	Discovery Command	SET Command	GET Command	ANSI/ PID
DISC_UNIQUE_BRANCH	✓			E1.20
DISC_MUTE	✓			E1.20
DISC_UN_MUTE	✓			E1.20
DEVICE_INFO			✓	E1.20
SUPPORTED_PARAMETERS			✓	E1.20
PARAMETER_DESCRIPTION			✓	E1.20
SOFTWARE_VERSION_LABEL			✓	E1.20
DMX_START_ADDRESS		✓	✓	E1.20
DEVICE_LABEL		✓	✓	E1.20
MANUFACTURER_LABEL			✓	E1.20
DEVICE_MODEL_DESCRIPTION			✓	E1.20
IDENTIFY_DEVICE		✓	✓	E1.20
FACTORY_DEFAULTS		✓	✓	E1.20
DMX_PERSONALITY		✓	✓	E1.20
DMX_PERSONALITY_DESCRIPTION			✓	E1.20
DISPLAY_LEVEL		✓	✓	E1.20
DMX_FAIL_MODE		✓	✓	E1.37
MODULATION_FREQUENCY		✓	✓	E1.37
LOCK_STATE		✓	✓	E1.37
LOCK_STATE_DESCRIPTION			✓	E1.37
LOCK_PIN		✓		E1.37

Parameter ID	Discovery Command	SET Command	GET Command	ANSI/ PID
SERIAL_NUMBER ¹⁾			✓	PID: 0xD400
DISPLAY_AUTO_OFF ¹⁾		✓	✓	PID: 0xD401
IDENTIFY_MODE ¹⁾		✓	✓	PID: 0xD402
FIRMWARE_UPDATE ¹⁾		✓		PID: 0xD408
CURVE_DEFINITION ¹⁾		✓	✓	PID: 0xD430
SOFT_DIMMING ¹⁾		✓	✓	PID: 0xD431
SUBDEVICE_ENABLE ¹⁾		✓	✓	PID: 0xFF0F

1) Manufacturer depending RDM control commands (MSC - Manufacturer Specific Type)

Manufacturer depending RDM control commands:

SERIAL_NUMBER

PID: 0xD400

Outputs a text description (ASCII-Text) of the device serial number.

GET Send: PDL=0
 Receive: PDL=21 (21 Byte ASCII-Text)

DISPLAY_AUTO_OFF

PID: 0xD401

Sets the time after which the display is switched off (DISPLAY_LEVEL = 0).

Valid values are:

- 0 - NO AUTO OFF
- 600 - 1 minute
- 1200 - 2 minutes
- 1800 - 3 minutes
- 2400 - 4 minutes
- 3000 - 5 minutes
- 3600 - 6 minutes
- 4200 - 7 minutes
- 4800 - 8 minutes
- 5400 - 9 minutes

GET Send: PDL=0
 Receive: PDL=2 (1 Word)

SET Send: PDL=2 (1 Word)
 Receive: PDL=0

IDENTIFY_MODE

PID: 0xD402

Sets the mode that is executed with IDENTIFY_DEVICE.

GET Send: PDL=0
 Receive: PDL=1 (1 Byte IDENTIFY_MODE_ID)

SET Send: PDL=1 (1 Byte IDENTIFY_MODE_ID)
 Receive: PDL=0

IDENTIFY_MODE_ID	Function
0	FULL Identify All outputs switch ON / OFF simultaneously and the status LED flashes
1	LOUD Identify The outputs switch ON / OFF one after the other and the status LED flashes
2	QUIET Identify The outputs do not switch, only the status LED flashes

FIRMWARE_UPDATE

PID: 0xD408

Carries out the firmware update of the device.

CURVE_DEFINITION

PID: 0xD430

Sets the LookUp tables of the device.

SOFT_DIMMING

PID: 0xD431

Sets the soft dimming behavior of the device.

GET Send: PDL=0
 Receive: PDL=1 (1 Byte SoftDimm-Parameter)

SET Send: PDL=1 (1 Byte SoftDimm-Parameter)
 Receive: PDL=0

Parameter	Function
0	Soft-Dimm OFF
1-255	Soft-Dimm up to the given value

SUBDEVICE_ENABLE

PID: 0xFF0F

Enable or disable the sub devices of the device.

GET Send: PDL=0
 Receive: PDL=1 (1 Byte SUBDEVICE_ENABLE_STATE)

SET Send: PDL=1 (1 Byte SUBDEVICE_ENABLE_STATE)
 Receive: PDL=0

SUBDEVICE_ENABLE_STATE	Function
0	SUB DEVICES DISABLED
1	SUB DEVICES ENABLED

Configure the Dimming-Curve (Curve Definition)

The **DMX-LED-Dimmer X9HRX+** has a free programmable dimming curve (Curve Definition) for each output.

The received DMX-Channel has values from 0 up to 255 (8Bit). The DMX-LED-Dimmer X9HR output driver provides 65536 steps (16Bit) which are assigned to the DMX values.

So, it is possible to effect with small steps little brightness changings in the lower brightness range. However, in the upper brightness range it's possible to program bigger steps.



If no dimming curve is configured (delivery status) the output control is linear.

Set dimming curve via RDM

The RDM parameter CURVE_DEFINITION is used to set the dimming curve / lookup tables.

For this parameter, the Program RDM Configurator offers the following interface for editing the dimming curve:

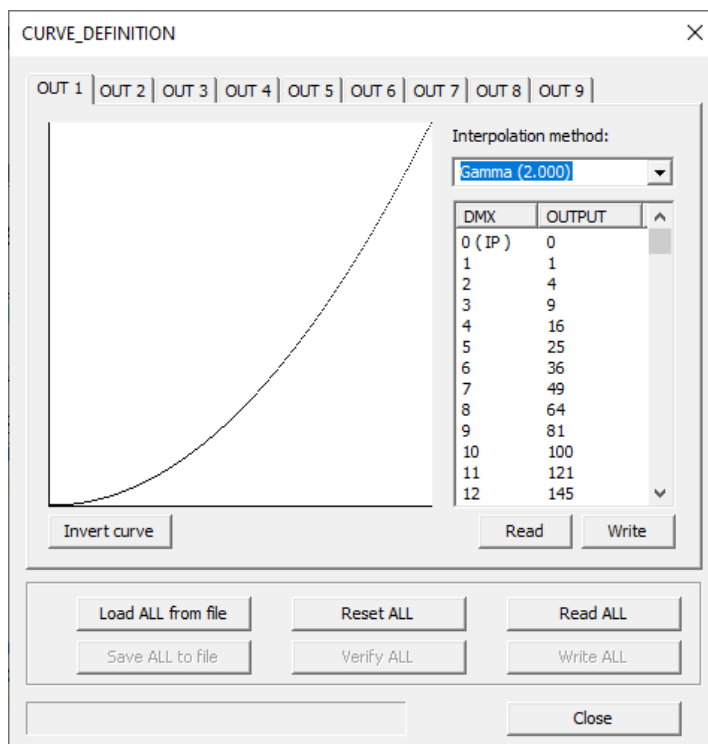

A detailed description of the functions can be found in the RDM Configurator manual.

Setting the output frequency

The DMX-LED-Dimmer X9HRX+ is able to generate several output frequencies on the LED outputs.

The output frequency is to set via the RDM-Parameter MODULATION_FREQUENCY.

The following output frequencies are available:

- 500 Hz
- 1000 Hz
- 2000 Hz
- 4000 Hz
- 8000 Hz



If dimming curves with low output values are used in combination with a low output frequency, a flickering can occur at the outputs due to APDM (Adaptive Pulse Density Modulation).

In this case, the output frequency must be increased.

Lock device settings

The RDM parameters *Lock Pin* and *Lock State* allow or prohibit changing saved RDM parameters.

Lock Pin

The four-digit pin code number for the lock function can be set using the Lock Pin parameter.

After entering the correct currently used PIN (Old PIN) in the RDM software (e.g. RDM Configurator), the new, desired PIN can be entered in the New PIN field and saved by setting the parameter.

When delivered, the lock pin is always 0000.

Lock State

The device settings can be locked or unlocked using the Lock State parameter.

The following lock states can be selected:

Value	Name	Description
0	Unlocked	Parameters are editable
1	RDM Locked	Parameters cannot be edited via RDM

When delivered, the device is always *Unlocked*.

The Lock Pin (PIN Code) is required to change the Lock State parameter.



The RDM parameters Identify Device, Reset Device and Display Level can always be executed, regardless of the lock state.

SubDevice-Mode

In the standard mode, the **DMX-LED-Dimmer X9HRX+** has a DMX start address from which the DMX channels are used in sequence.

Within the SubDevice mode, each output is assigned with its own DMX address and DMX-FAIL action.

The active RGB-Master-Dimmer is an exception. If this is active, the DMX start address and the DMX FAIL behavior can be set for each RGB group with the master dimmer.

To activate and deactivate the SubDevice mode, the SUBDEVICE_ENABLE parameter must be activated via RDM.

Then, the DMX address and the DMX-FAIL behavior for each output / RGB group can be set via RDM.

The DMX addresses are assigned as follows in SubDevice mode:

9Ch. Dimmer 8Bit

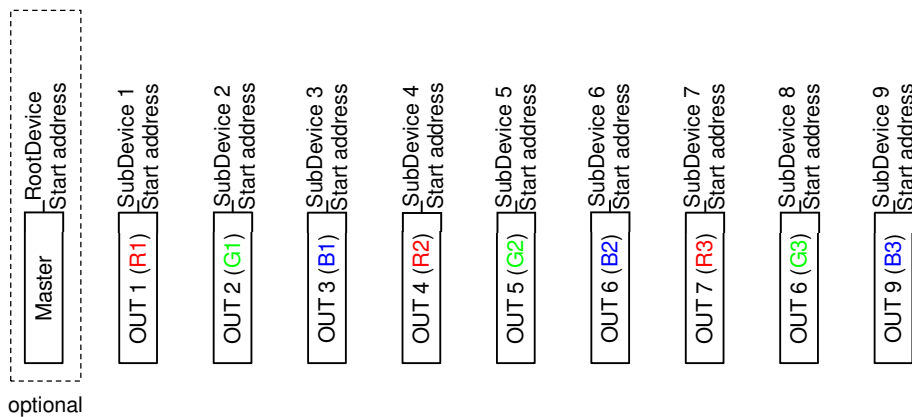

The DMX addresses can be freely assigned to the outputs in SubDevice mode. Several outputs can also use the same DMX address.

9Ch. Dimmer 16Bit

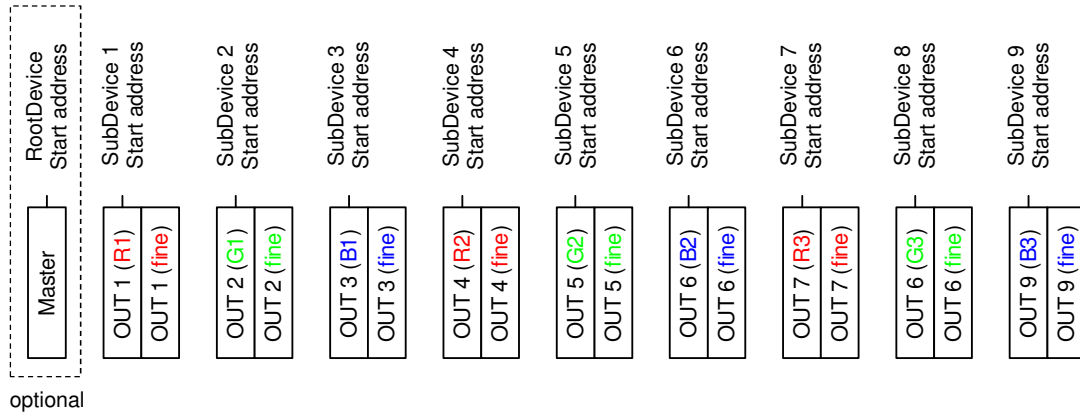

9Ch. Dimmer 8Bit with RGB-Master-Dimmer

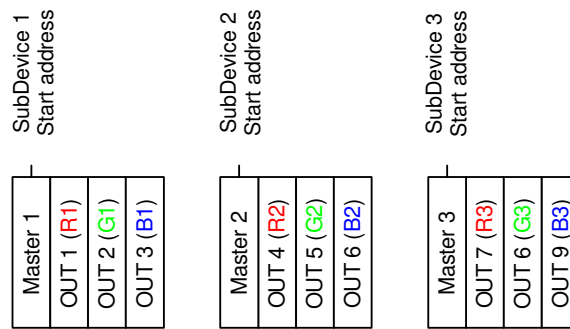

9Ch. Dimmer 8Bit with RGBW-Master-Dimmer

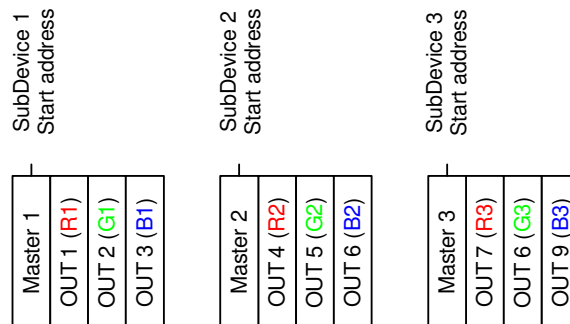

Firmware-Update

The **DMXLED-Dimmer X9HRX+** has an update function that allows to transfer current firmware versions. This can be carried out via RDM or USB.



If an error occurs during the update, you can start from the beginning at any time. If a wrong firmware is installed, a firmware update may only be possible via USB!

Proceed as follows the **Firmware Update via RDM:**

- Switch off the device and connect it to an ArtNet-DMX/RDM gateway
- Start the RDM Configurator software
- Select RDM parameter Firmware update
- Select SET parameter or double-click on the parameter
- Select firmware file (.bin) and confirm
- Wait until the update is complete

Proceed as follows the **Firmware Update via USB:**

- Turn off the device (disconnect power supply and USB connection !)
- Switch 7, 8 and 10 on ON
- Set switch 9 on OFF
- Generate USB connection to PC
- Install the USB driver if necessary (check in the device manager)
- Start the Update-Software **DMX4ALL USB-Updater**
- Select DMX-LED-Dimmer X9HRX from list
- Click *Firmware-Update*
- Select Firmware file (.bin) and confirm
- Wait until update has finished
- Turn off the device (disconnect power supply and USB connection !)
- Reset switch to original setting



No program may access the USB connection. Close the DMX-Configurator and USB-Updater before connecting the USB cable to the DMX-LED-Dimmer X9HRX. Start the USB Updater only, when the DMX LED Dimmer X9HRX is in update mode.

If an error occurs during the update, you can start from the beginning at any time.

Factory Reset



Before Factory Reset, read all steps carefully.

To reset the **DMX-LED-Dimmer X9HRX+** to delivery status, proceed as follows:

- Turn off device (disconnect power supply and USB connection !)
- Set DIP switch 1 up to 10 to ON
- Turn on device (connect power supply)
- The LED lights up 20x during ca. 3 seconds
 - ➔ While the LED lights up set DIP switch 10 to OFF
- Now, the Factory Reset is executed
 - ➔ The LED lights up with error code 4
- Turn off device (disconnect power supply !)
- Now, the device can be used



If a Factory Reset is needed again, this procedure can be repeated at any time.

Dimensions

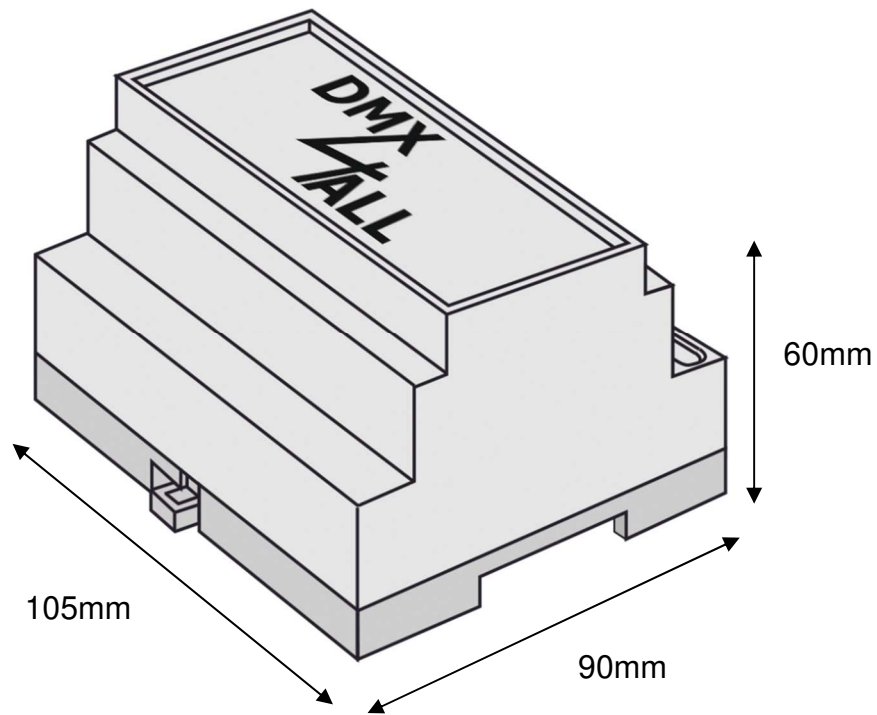

All details in mm

Equipment

Power supply 12V



USB cabel A → Mini B 5pol.



Revision History

Firmware V1.00

- First Release

CE-Conformity



This assembly (board) is controlled by a microprocessor and uses high frequency. In order to maintain the properties of the module with regard to CE conformity, installation into a closed metal housing in accordance with the EMC directive 2014/30/EU is necessary.

Disposal



Electronical and electronic products must not be disposed in domestic waste. Dispose the product at the end of its service life in accordance with applicable legal regulations. Information on this can be obtained from your local waste disposal company.

Warning



This device is no toy. Keep out of the reach of children. Parents are liable for consequential damages caused by nonobservance for their children.

Risk-Notes



You purchased a technical product. Conformable to the best available technology the following risks should not be excluded:

Failure risk:

The device can drop out partially or completely at any time without warning. To reduce the probability of a failure a redundant system structure is necessary.

Initiation risk:

For the installation of the board, the board must be connected and adjusted to foreign components according to the device paperwork. This work can only be done by qualified personnel, which read the full device paperwork and understand it.

Operating risk:

The Change or the operation under special conditions of the installed systems/components could as well as hidden defects cause to breakdown within the running time.

Misusage risk:

Any nonstandard use could cause incalculable risks and is not allowed.

Warning: It is not allowed to use the device in an operation, where the safety of persons depend on this device.



DMX4ALL GmbH
Reiterweg 2A
D-44869 Bochum
Germany

Last changes: 20.11.2024

© Copyright DMX4ALL GmbH

All rights reserved. No part of this manual may be reproduced in any form (photocopy, pressure, microfilm or in another procedure) without written permission or processed, multiplied or spread using electronic systems.

All information contained in this manual was arranged with the greatest care and after the best knowledge. Nevertheless, errors are to be excluded not completely. For this reason, I see myself compelled to point out that I can take over neither a warranty nor the legal responsibility or any adhesion for consequences, which decrease/go back to incorrect data. This document does not contain assured characteristics. The guidance and the characteristics can be changed at any time and without previous announcement.