

DMX-ADDRESS-MODULE

User Manual

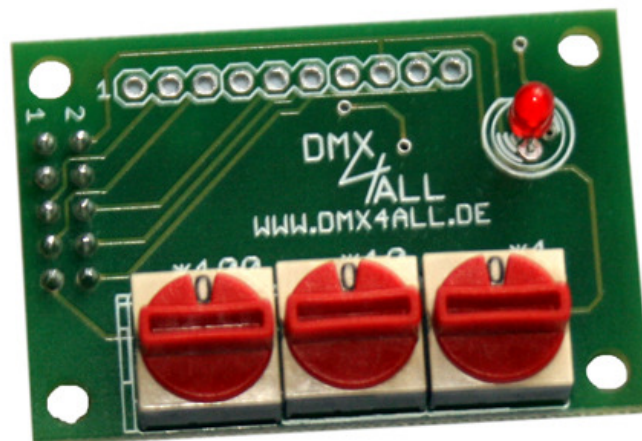

DMX
4
ALL
WWW.DMX4ALL.EU

Specification

The **DMX-Address-Module** is a useful add-on, which can be connected to the DMX data line. A starting address of any DMX device, which is connected behind the DMX-Address-Module, can be centrally adjusted by it.

The DMX devices, which are connected behind the DMX-Address-Module, react to their adjusted starting address plus the address of the DMX-Address-Module minus one.

Resulting address = DMX-Address-Module address + device address - 1

Example:

DMX-Address-Module address	Device address	Resulting address
1	1	1
15	1	15
1	15	15
15	15	29

Note: If only one DMX device is be driven by the DMX-Address-Module the starting address of this device should be set to one, so the resulting address is equal to the address of the DMX-Address-Module

Example of a configuration with 2x 6 DMX controlled outputs and one centrally adjusted DMX address by the DMX-Address-Module:

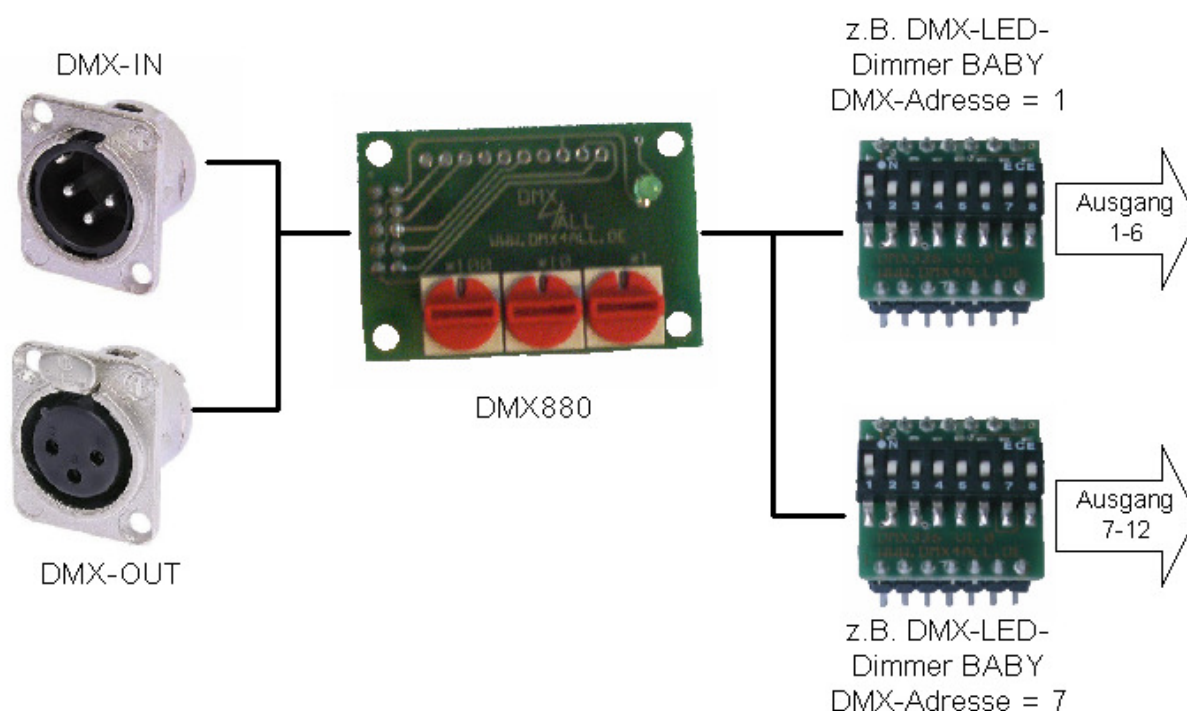

Data Sheet

Voltage supply:	5V DC / 50mA
DMX-input:	DMX-signal / 1 LOAD-UNIT
DMX-channels:	none
DMX-output:	DMX-signal for 32 LOAD-Units
Envelope delay:	ca. 0,1µs
Board Dimension:	30mm x 45mm

LED-Display-Codes

The integrated DMX-LED is used as a multifunctional display. This LED lights nonstop in normal operation. If the LED does not light, there is no DMX512-input-signal.

Also the LED signalled the operation status. In this case the LED lights up in short pitches and then turns into off modus. The Number of flashing signals is equal to the Number of the error status:

Error Status	Error	Description
1	No DMX	Please check the DMX signal
2	Address error	Check if a valid DMX-starting address is adjusted.
3	DMX-signal error	An invalid DMX input signal is established.

DMX-ADDRESS-MODULE Connectors

PIN	FUNKTION	PIN	FUNKTION
1	GND	2	+5V IN
3	GND	4	GND
5	DMX+ IN	6	DMX+ OUT
7	DMX- IN	8	DMX- OUT
9	SDA	10	SCL

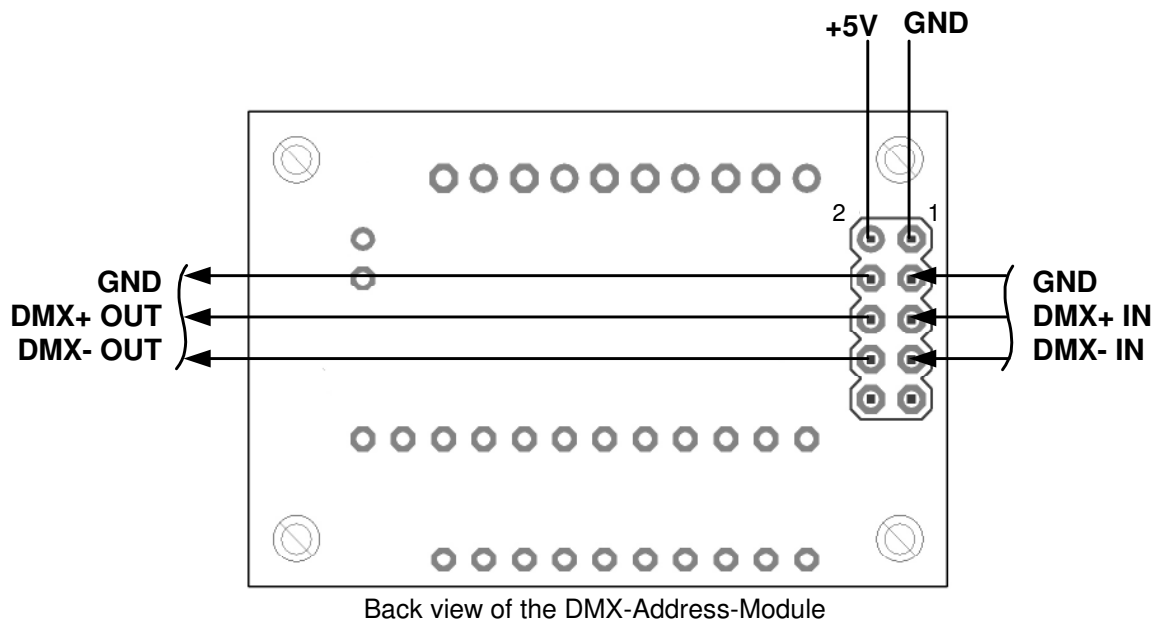

TWI-Interface

The adjusted value of the DMX-Address-Module can be readout by the TWI-Interface. The SDA- and SCL- connector can establish a connection to use the TWI Interface.

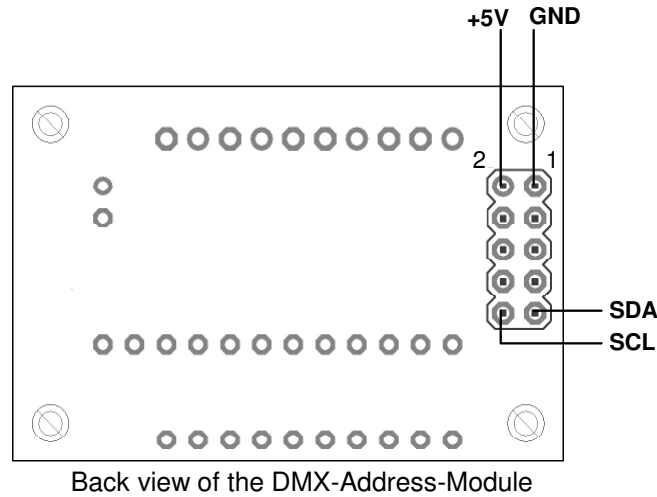

Addressing

The DMX-Address-Module comes with the hardware address 0b0100111x. The last bit R/W must be set so the DMX-Address-Module data can be readout.

Timing Diagram

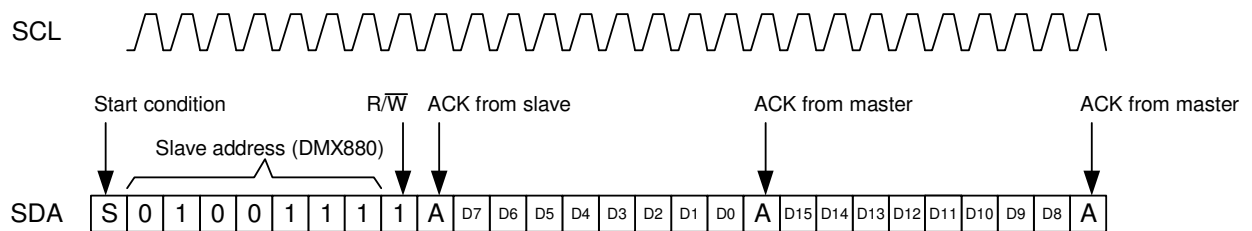

DMX-ADRESS-MODULE Dimensions:

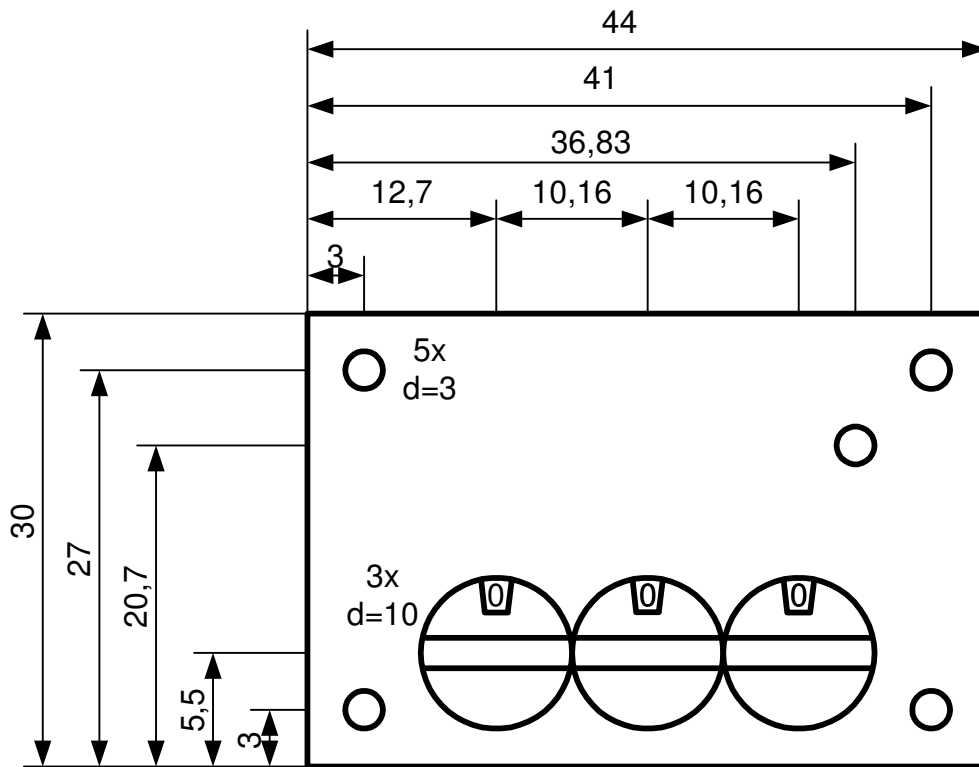

All details in mm

CE-conformity

This assembly (board) is controlled by a microprocessor and uses high frequency. To get the characteristics of the assembly in relation to the CE-conformity, an installation in a compact metal casing is necessary.

Risk-Notes

You purchased a technical product. Conformable to the best available technology the following risks should not be excluded:

Failure risk: The device can drop out partially or completely at any time without warning. To reduce the probability of a failure a redundant system structure is necessary.

Initiation risk: For the installation of the board, the board must be connected and adjusted to foreign components according to the device paperwork. This work can only be done by qualified personnel, which read the full device paperwork and understand it.

Operating risk: The Change or the operation under special conditions of the installed systems/components could as well as hidden defects cause to breakdown within the running time.

Misusage risk: Any nonstandard use could cause incalculable risks and is not allowed.

Warning: It is not allowed to use the device in an operation, where the safety of persons depends on this device.



DMX4ALL GmbH
Reiterweg 2A
D-44869 Bochum
Germany

© Copyright 2012 DMX4ALL GmbH

All rights reserved. No part of this manual may be reproduced in any form (photocopy, pressure, microfilm or in another procedure) without written permission or processed, multiplied or spread using electronic systems.

All information contained in this manual was arranged with the greatest care and after the best knowledge. Nevertheless, errors are to be excluded not completely. For this reason, I see myself compelled to point out that I can take over neither a warranty nor the legal responsibility or any adhesion for consequences, which decrease/go back to incorrect data. This document does not contain assured characteristics. The guidance and the characteristics can be changed at any time and without previous announcement.