

DMX-Player L

User Manual

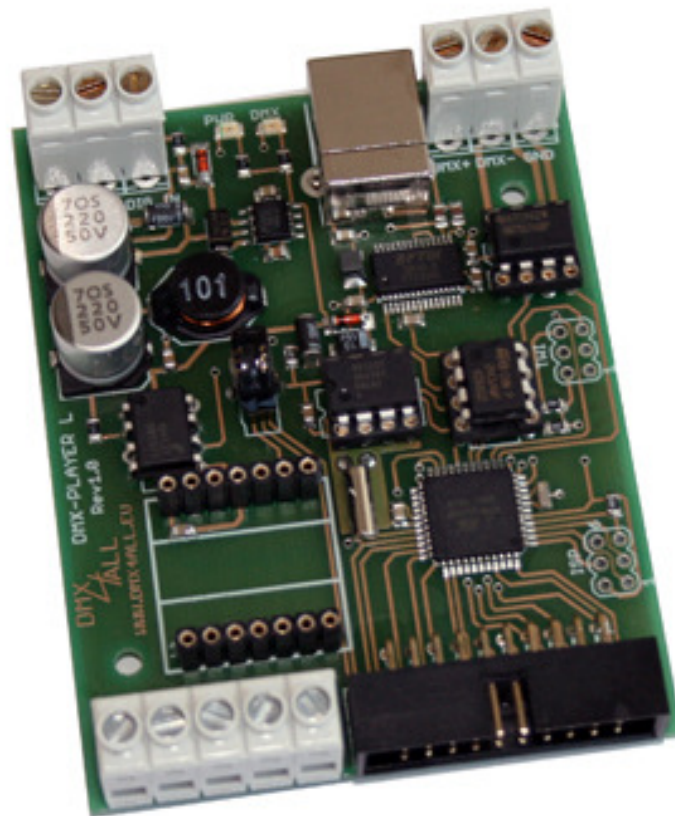

Description

The **DMX-Player L** is a DMX-StandAlone device. The scenes provided in the PC can be loaded by USB on the device. Without PC the deposited scenes will be reproduced. The selection of the Scene can occur in different way. An application in the live operation with connected PC is as possible.

Due to the easy handling the application is possible in decoration and presentation sections.

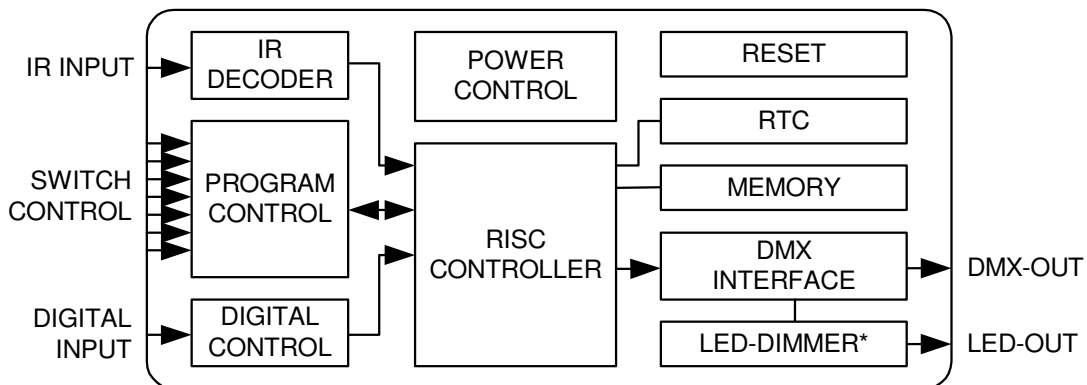

Energy Saving Design:

By modern switch-power-supply-technology it will be generated less warmth considerably and therefore the energy consumption is lowered.

Data Sheet

Voltage supply:

7-24V DC / 250mA (Without LED-Dimmer BABY)

DMX-OUT:

channels

Internal clock (RTC)

Digital control-input for control per button

Program-Trigger up to 16 Timer possible

Brightness-control per UP/DOWN button, Poti or IR

Playback rate per UP/DOWN button, Poti or IR

scenes Selection:

first 10 per button

first 16 per button-Matrix 4x4

first 25 per button-Matrix 5x5

up to 250 scenes per numerical keypad with ENTER and BLACKOUT

first 10 per RC5 IR-remote control

- USB-Connection to transfer of the scenes or as a PC DMX-Interface in the live operation
- 8Kbyte Stand-Alone-Memory (up to 32kByte with 24C256 possible)
- DMX-LED-Dimmer BABY slip-on

Board-dimensions:

64,2mm x 82mm

Installation USB

The Interface installation happens in two parts.

Part 1: Installation the USB-driver

- Put the DMX interface to a free USB port of your PC.
There appears the announcement which was found new hardware.

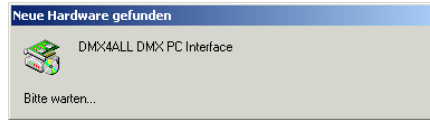

- Follow the hardware assistant and select for the drivers source *Other Source specify* and afterwards the place for the driver (e.g.: with the provided disk).
- Certify the located driver with *Next* and complete the driver's installation with *Finish/Complete*.

Part 2: Installation Vitrual COM-Port

- After the installation of the USB driver a USB-Serial-Port will be automatically identify.
There also appears the announcement *new hardware was found*.



- Follow the hardware assistant and select for the drivers source *Other Source specify* and afterwards the place for the driver (e.g.: with the provided disk).
- Certify the located driver with *Next* and complete the driver's installation with *Finish/Complete*.

For the installation of the USB please use the drivers on the attached data carrier. You can download the drivers in the most topical version on the Internet (www.dmx4all.eu).



The installation can differ according to the used operating system and driver's version.

Connections

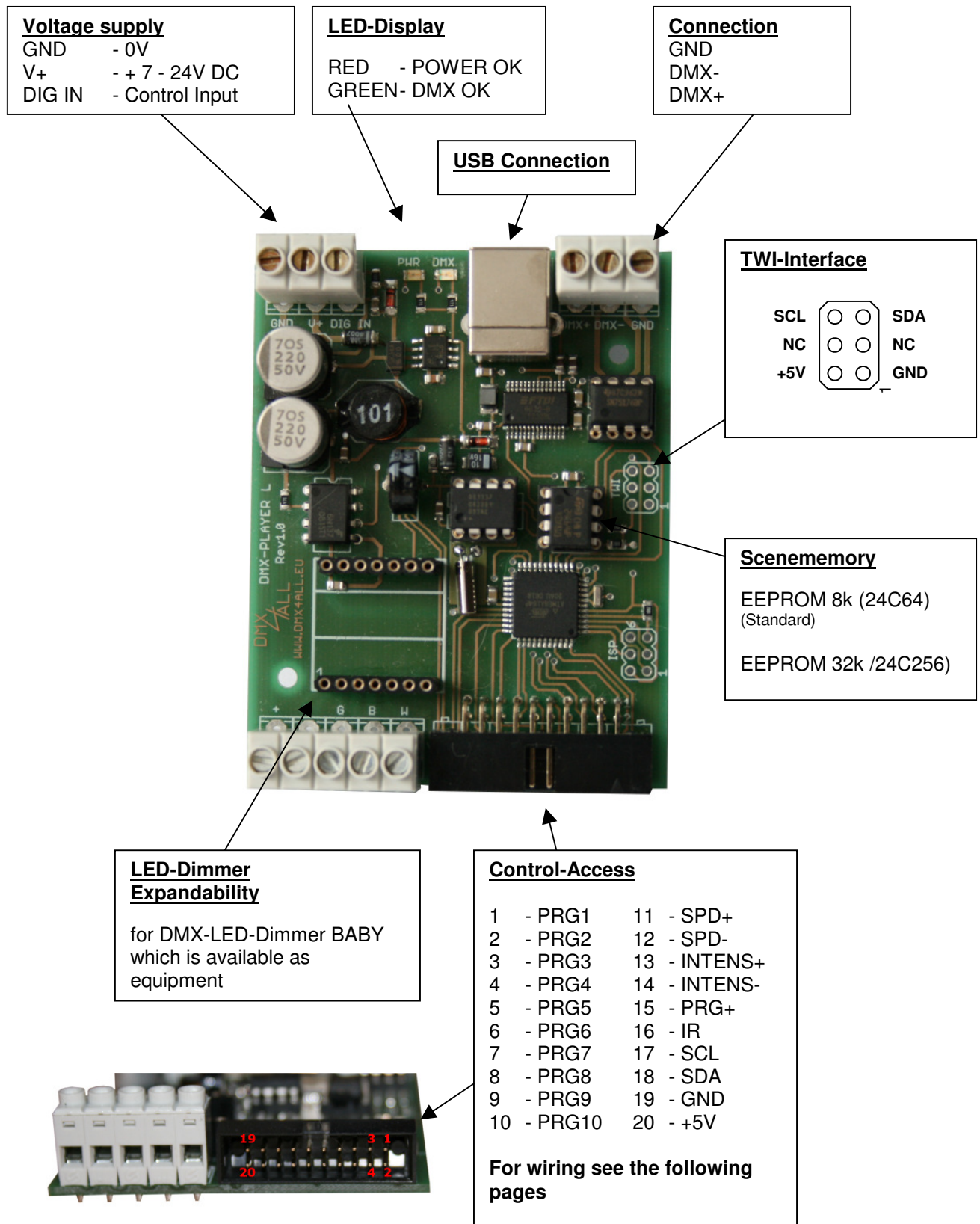

Program selection

The selection of the deposited scenes can be effected with different wirings. Which wiring is used, must be configured in the Setup-Menu or the DMX-Configurator (For this see the part Configuration).



The last selected scene will be recorded and after re-starting automatically launched.

► See „Running one scene after power on“

Selection per 10 button

The first 10 stored scenes can be called directly about up to 10 buttons.

Connection:

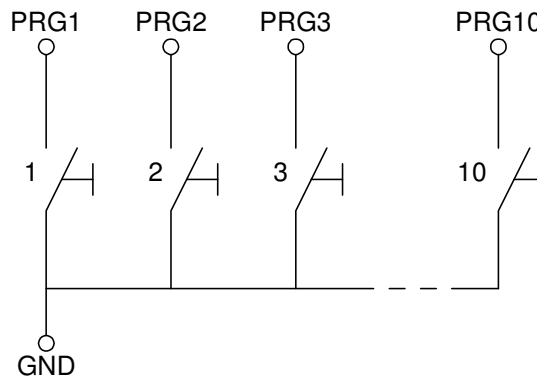

Selection about Button-Matrix 4x4 or 5x5

With a Matrix-wiring it is possible to call up to 25 Programs per one button.

Connection Matrix 4x4:

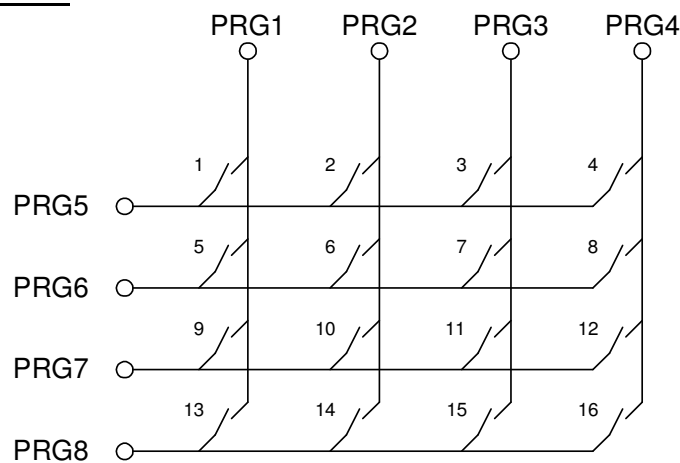

Connection Matrix 5x5:

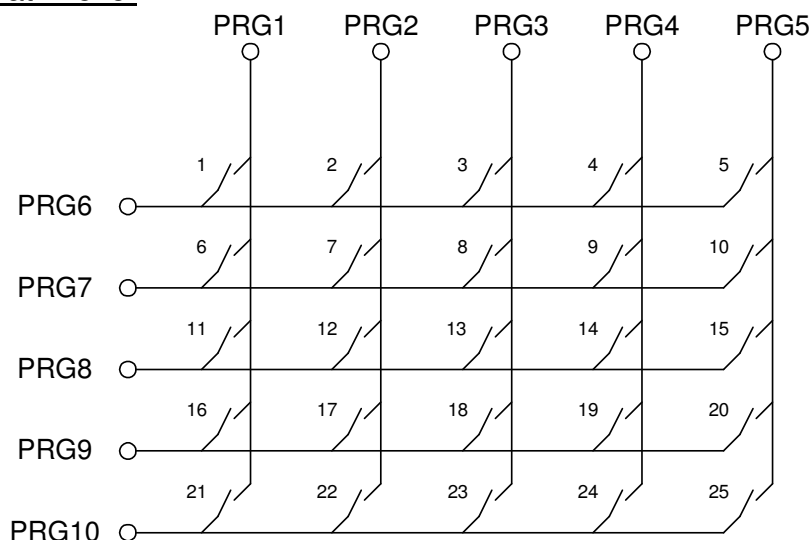

Selection about numeric keypad with ENTER and BLACKOUT

The input of the executive Scene happens with the numeric keypad and next ENTER. The programs 1 up to 250 are possible.

In addition, with the switch BLACKOUT the blackout function can be switched-on and switched-off with the key. The button ENTER automatically switches off the blackout function.

Exampel: Scene 28: ,2' + ,8' + ,ENTER'
Scene 146: ,1' + ,4' + ,6' + ,ENTER'

Connection:

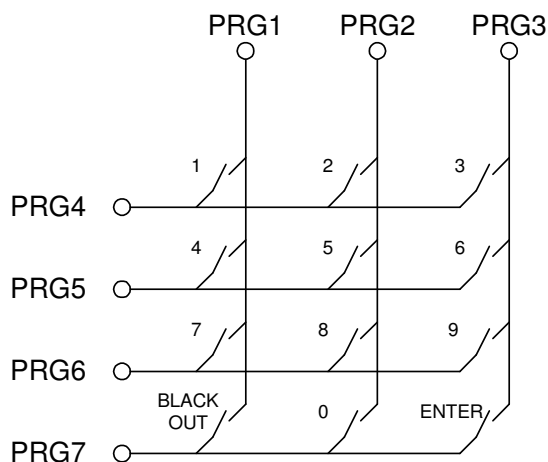

Selection about 8-Bit-BCD Signal

With a BCD control-signal up to 250 Scenes can be called. Therefore the 8 bits of the BCD signal to the entrances PRG1 to PRG8 have to be established.

Brightness Setting

The brightness setting can be carried out per UP/DOWN button or Potentiometer.

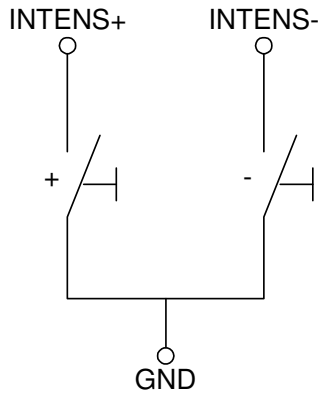

Wiring with UP/DOWN button

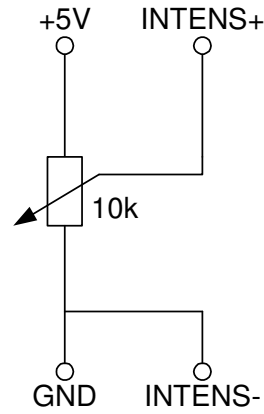

Wiring with Potentiometer



During the operation the brightness value will be saved with the UP/DOWN-button and retained during shutdown the DMX-Player L.

Speed Setting

The speed setting can be carried out per UP/DOWN button or Potentiometer.

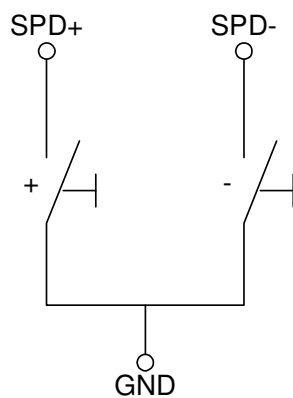

Wiring with UP/DOWN button

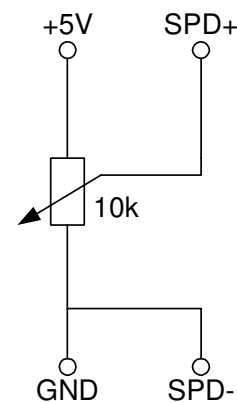

Wiring with Potentiometer



During the operation the speed value will be saved with the UP/DOWN-button and retained during shutdown the DMX-Player L.

Program StandAlone-function

The **DMX-Player L** has a user programmable StandAlone-function. The Scenes arranged in the PC (programmes) will be transferred once to the interface and then can be replayed.

The software DMX-Configurator serves for the production and programming of the scenes. Under the menu point *Settings*→*Communication settings* the interface above which the DMX-Configurator finds the connected hardware will be set.

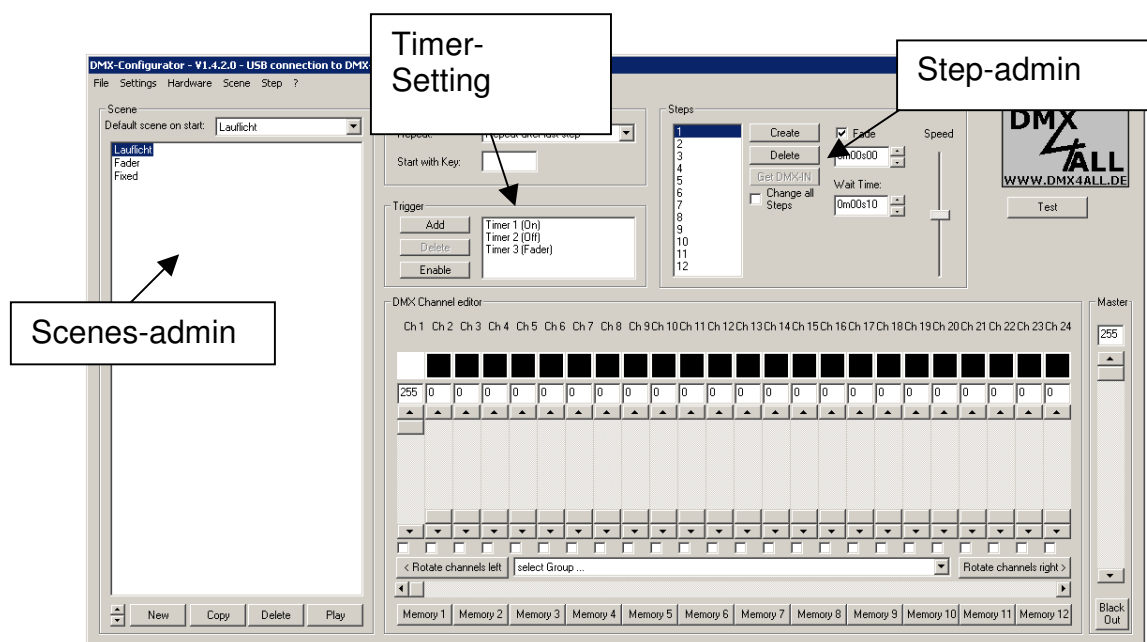

In the left part there is the scenes admin. Here the scenes can be set up and fixed in the order.

The right part shows the step admin. Every Scene exists of one step at least. For the setting of different DMX values there are controller available. These are marked with the channel number. To reach all 512 DMX channels, you must select the DMX channel area with the underneath horizontal racketeer. For every step different DMX-values can be set for every channel.

Furthermore for every step the fade time and residence time will be set with **Fade Time** and **Wait Time**.

You can write the provided scenes in the Stand-Alone-memory of the DMX player "S". The transfer of the scenes to the interface can be started under *Hardware*→*Write data*.

Attention: This process can last some time! Please, do not break off the transfer and wait for certification of the DMX-Configurators.

Executing a Scene after starting

After starting a specific scene can be replayed. For this, by compiling the scene in the DMX-Configurator the *Default Scene on Start* have to be denoted. If this is denoted, the selected scene under *Default Scene on Start* will be achieved by starting the DMX-Player L.

Configuring the DMX-Player L

The DMX-Player L can be configured about the DMX-Configurator from the version 1.5. Select therefore *Settings*→*Hardware settings* by connected DMX-Player L. It appears the following dialogue:

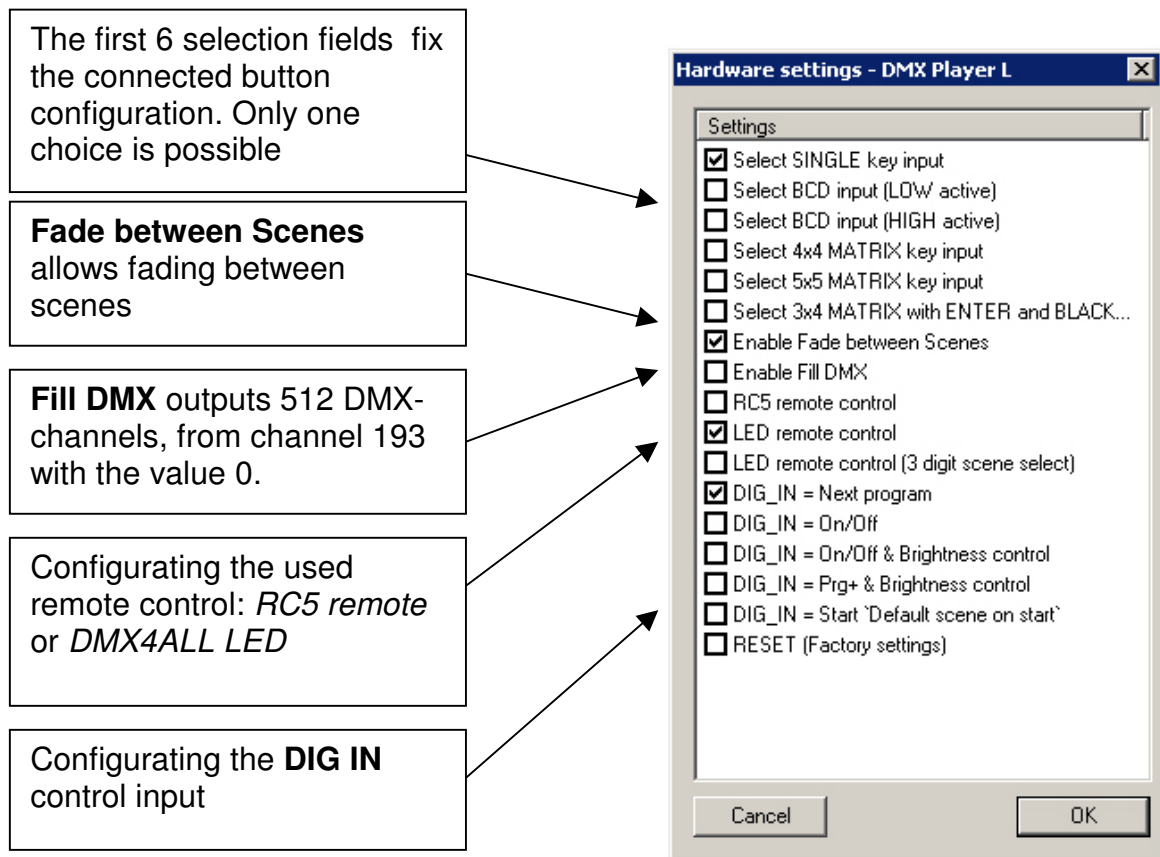

The configuration is transferred and stored by **OK** to the DMX player L.

Internal Clock (RTC)

The **DMX player L** disposes of an internal clock with which scenes can be start at adjustable times.

Time setting

Select in the DMX-Configurator
Hardware→*Synchronize Clock* .
Now the topical PC-PC-system-time will
transferred on the DMX player L.

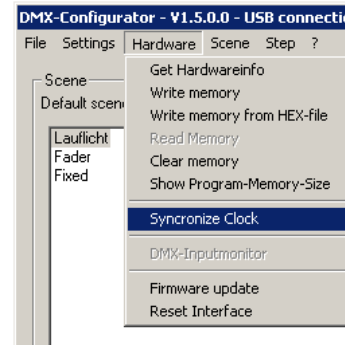

Digital Input Control DIG IN

The digital Input Control **DIG-IN** of the DMX-Player L can be configured as follows:
(see DMX-Player L configurating)

- Process next program
- Switch On/AOFF
- ON/OFF (short activity)
and brightness setting (long activity)
- Process next program (short activity)
and brightness setting (long activity)
- Process „Default scene on start”

The wiring of the Input control will be carried out as shown in the following view:

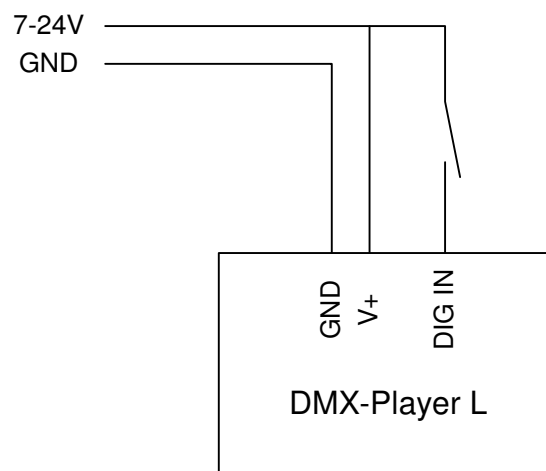

IR-Operation

The DMX player L allows an IR-Operation by means of external IR-Sensor. An IR-Sensor is connected to the Pin 16 of the Control connection.

The stored scenes can be called by IR-remote control.
The DMX player L can be used by DMX4ALL LED remote control.

Operating with DMX4ALL LED-remote control

The program selection happens about the keys **1,2,3 ... 9,0** according to the programs from the 1 up to 9. The key 0 is for a free colour setting.

About the keys **+** and **-** the brightness and the speed is adjustable as well as is possible for a program selection.

After actuating the key **SPEED**, the speed is adjustable;

After actuating the key **PROG SELECT**, the programs are selectable;

After actuating the key **R, G** or **B**, the brightness is adjustable.

A separate setting for Red, Green and Blue is not possible.

The switch **BLACK OUT** activates and deactivates the BlackOut-function. Besides the brightness setting will be persist.

The switch **FLASH** activates and deactivates the Flash-function, which engaging all Channels on 100%. Besides the brightness setting will be persist.



CE-conformity



This assembly (board) is controlled by a microprocessor and uses high frequency (8MHz). To get the characteristics of the assembly in relation to the CE-conformity, an installation in a compact metal casing is necessary.

Risk-Notes

You purchased a technical product. Conformance to the best available technology the following risks should not be excluded:

Failure risk: The device can drop out partially or completely at any time without warning. To reduce the probability of a failure a redundant system structure is necessary.

Initiation risk: For the installation of the board, the board must be connected and adjusted to foreign components according to the device paperwork. This work can only be done by qualified personnel, which read the full device paperwork and understand it.

Operating risk: The Change or the operation under special conditions of the installed systems/components could as well as hidden defects cause to breakdown within the running time.

Misusage risk: Any nonstandard use could cause incalculable risks and is not allowed.

Warning: It is not allowed to use the device in an operation, where the safety of persons depend on this device.



DMX4ALL GmbH
Reiterweg 2A
D-44869 Bochum
Germany

© Copyright 2010 DMX4ALL GmbH

All rights reserved. No part of this manual may be reproduced in any form (photocopy, pressure, microfilm or in another procedure) without written permission or processed, multiplied or spread using electronic systems.

All information contained in this manual was arranged with largest care and after best knowledge. Nevertheless errors are to be excluded not completely. For this reason I see myself compelled to point out that I can take over neither a warranty nor the legal responsibility or any adhesion for consequences, which decrease/go back to incorrect data. This document does not contain assured characteristics. The guidance and the characteristics can be changed at any time and without previous announcement.